



## universal and compatible

These compact scan heads from SCANLAB provide optimal solutions for nearly all challenges found in industrial laser materials processing. The mechanically and electrically inter-compatible scan heads have apertures ranging from 7 to 30 mm and various levels of dynamics. High long-term stability and low drift values are ensured via integrated temperature stabilization.

SCANLAB has products for practically every customer need. Small-aperture systems optimally combine top speed and exceptional precision. Marking speeds exceeding 1000 characters per second can be achieved.

Also available are large-aperture scan heads offering small spot size, high speed and laser-power handling up to the multi-kilowatt range.

The housing concept as well as tight manufacturing and assembly tolerances bring high flexibility and certainty to the design and operation of laser materials processing systems. This also facilitates speedy adaptation to individual customer requirements.

hurrySCAN III scan heads take advantage of the new dynAXIS 3 series galvanometer scanners. In conjunction with new electronics, these galvos deliver highest dynamic performance, lowest drift and best linearity.

### Typical Applications:

- Materials processing
- Marking
- Microstructuring
- Rapid manufacturing
- 3D applications
- Processing-on-the-fly

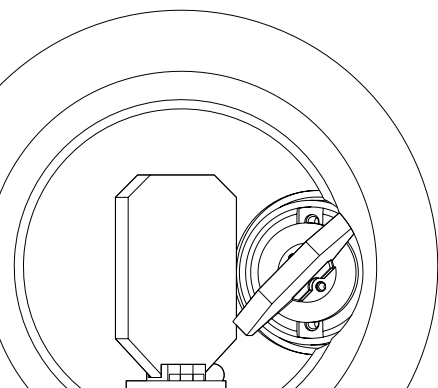

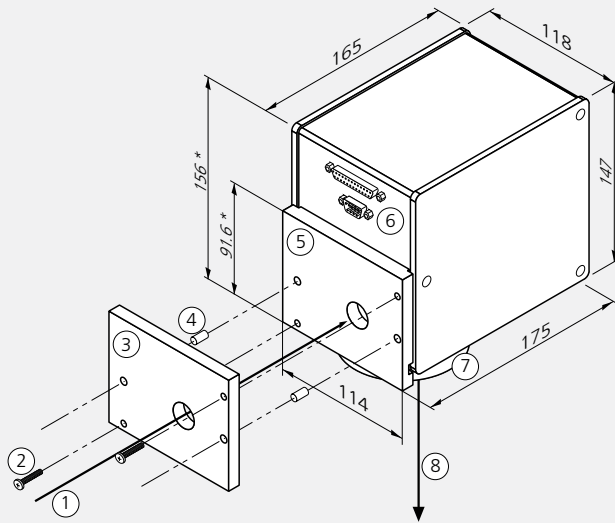

Denoted dimensions refer to the **standard housing** type with 10 mm aperture.  
 Variations in height and depth of the housing are possible; also housings with water cooling have other dimensions.

### Legend

- 1 Beam in
  - 2 Screws (M6 thread)<sup>(#)</sup>
  - 3 Flange<sup>(#)</sup>
  - 4 Alignment pins ( $\phi_{6,6}$ )<sup>(#)</sup>
  - 5 Mounting bracket
  - 6 Connectors
  - 7 Objective
  - 8 Beam out
- <sup>(#)</sup> not included

all dimensions in mm

### Beam Exit Side with Beam Displacement

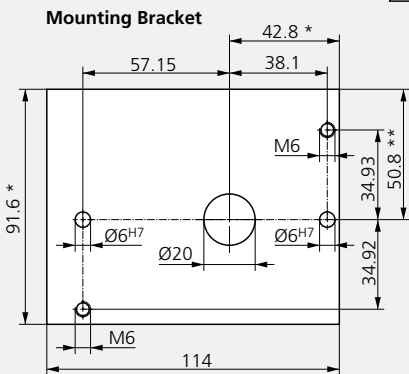
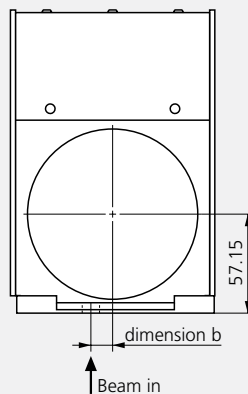

**Standard mounting bracket** (10 mm aperture): rectangular, without cut-out

\* The hurrySCAN II 7's mounting bracket is higher (101.6 mm instead of 91.6 mm) and the bore holes are horizontally displaced (45.3 mm instead of 42.8 mm).

\*\* True for 10 mm aperture scan heads, for hurrySCAN II 14 and hurrySCAN III 14 the dimension is 50.1 mm.

### Dimensions

Aperture	7 mm	10 mm	14 mm
Beam displacement (dimension b)	9.98 mm	12.56 mm	16.42 mm

### Optics

Scan mirrors and objectives with optimized mounts are available for all typical laser types and working fields.

To optimally utilize standard objectives, the hurrySCAN 25's two scan axes have differing maximum scan angles. This results in an elliptical image field with the larger semi-axis perpendicular to the entrance beam axis.

### Control

All scan heads of these series are equipped with either analog or digital standard interfaces and are easily controlled via SCANLAB's RTC control boards. All scan heads are optionally available with an optical fiber data interface.

### Attachment Provisions

Threaded and non-threaded holes at the housing's beam entrance side of hurrySCAN 20, 25 and 30 facilitate mounting of the scan head and installation of fiber optic outputs.

On the beam exit side, threaded holes are available for attaching add-on components such as cross jets, illumination, distance sensors or thermal shields.

### Cooling

The hurrySCAN 20, 25 and 30 scan heads provide water-cooling connections for the entrance aperture, electronics and galvanometer scanners, along with air-cooling of the deflection mirrors. This ensures constant working conditions and excellent long-term stability, thus guaranteeing reliable operation even in high-laser-power applications.

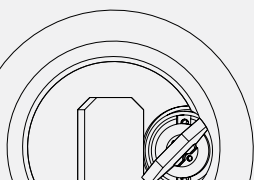

## Options

- varioSCAN: upgrade to a 3-axis scan system (hurrySCAN 20, 25 and 30 also with varioSCAN 40<sub>FLEX</sub>)
- High-performance variants with light-weight mirrors (14 mm apertures and higher)
- Available as a scan module without housing (except hurrySCAN 30)
- Water and air cooling (10 mm apertures and higher; standard for hurrySCAN 20, 25 and 30)
- Camera adapter for optical process monitoring

## Quality

The high quality of SCANLAB's scan heads is the result of years of experience in the development and manufacture of galvanometer scanners and scan systems. In addition, every scan system must first pass the SCANcheck burn-in test before it is released for shipment to the customer.

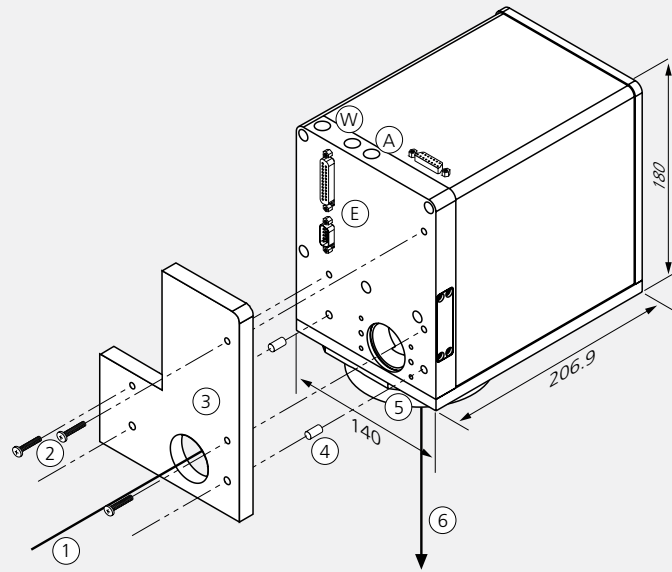

### Legend

- 1 Beam in
  - 2 Mounting screws (M6 threads)<sup>(#)</sup>
  - 3 Flange<sup>(#)</sup>
  - 4 Alignment pins (6<sub>h6</sub>)<sup>(#)</sup>
  - 5 Objective
  - 6 Beam out
  - 7 Wider construction (drawn dashed) only for hurrySCAN 30
- E Electrical connectors  
A Connection for cooling air  
W Connections for cooling water

<sup>(#)</sup> not included

all dimensions in mm

### Beam entrance side

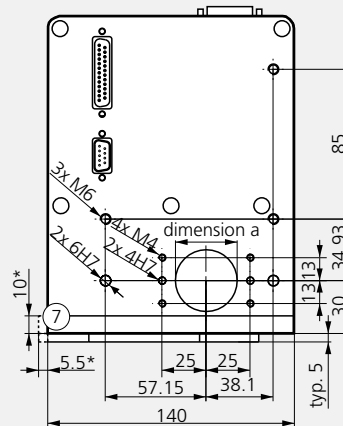

### Beam exit side with beam displacement

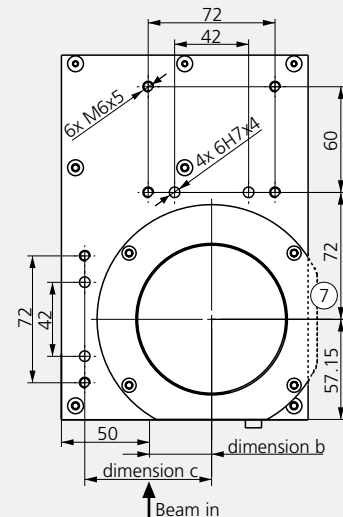

Dimensions	hurrySCAN 20	hurrySCAN 25	hurrySCAN 30
Aperture (dimension a)	20 mm	25 mm	30 mm
Beam displacement (dimension b)	25.25 mm	29.88 mm	35.53 mm
Dimension c	67.25 mm	72.00 mm	72.00 mm

## Type-Dependent Specifications

	hurrySCAN III 10	hurrySCAN III 14
<b>Aperture</b>	10 mm	14 mm
<b>Tracking error</b>	0.12 ms	0.18 ms
<b>Step response time<sup>(1)</sup></b>		
1% of full scale	0.35 ms	0.35 ms
10% of full scale	1.7 ms	1.2 ms
<b>Typical speeds<sup>(2)</sup></b>		
Marking speed	3.0 m/s	2.0 m/s
Positioning speed	12 m/s	12 m/s
Writing speed		
Good writing quality	1000 cps	660 cps
High writing quality	700 cps	410 cps
<b>Long-term drift</b>		
8-h-drift (after 30 min warm-up) <sup>(3)</sup>		
Offset	< 100 µrad	< 100 µrad
Gain	< 100 ppm	< 100 ppm
24-h-drift (after 3 h warm-up) <sup>(3)</sup>		
Offset	< 100 µrad	< 100 µrad
Gain	< 100 ppm	< 100 ppm
<b>Temperature drift</b>		
Offset	< 15 µrad/K	< 15 µrad/K
Gain	< 25 ppm/K	< 25 ppm/K
<b>Optical performance</b>		
Typical scan angle of scanner 1	±0.35 rad	±0.35 rad
Typical scan angle of scanner 2	±0.35 rad	±0.35 rad
Typical field size – square <sup>(2), (4)</sup>	110 x 110 mm <sup>2</sup>	90 x 90 mm <sup>2</sup>
Nonlinearity	< 0.9 mrad / 44°	< 0.9 mrad / 44°
<b>Weight</b> (without objective)	approx. 3 kg <sup>(5)</sup>	approx. 3 kg <sup>(5)</sup>

(all angles are in optical degrees)

## Type-Dependent Specifications

	hurrySCAN II			hurrySCAN			
<b>Aperture</b>	7 mm	10 mm	14 mm	10 mm	20 mm	25 mm	30 mm
<b>Tracking error</b>	0.11 ms	0.12 ms	0.24 ms	0.18 ms	0.35 ms	0.50 ms	0.55 ms
<b>Step response time<sup>(1)</sup></b>							
1% of full scale	0.23 ms	0.35 ms	0.40 ms	0.35 ms	0.80 ms	0.90 ms	1.20 ms
10% of full scale	-	1.70 ms	1.60 ms	0.90 ms	2.50 ms	3.20 ms	4.50 ms
<b>Typical speeds<sup>(2)</sup></b>							
Marking speed	3.5 m/s	3.0 m/s	1.5 m/s	2.0 m/s	1.0 m/s	0.8 m/s	0.7 m/s
Positioning speed	15.0 m/s	12.0 m/s	7.0 m/s	7.0 m/s	6.0 m/s	5.0 m/s	3.0 m/s
Writing speed							
Good writing quality	1100 cps	1000 cps	500 cps	640 cps	320 cps	260 cps	220 cps
High writing quality	800 cps	700 cps	340 cps	400 cps	210 cps	170 cps	150 cps
<b>Long-term drift</b> (8-h-drift)	< 0.3 mrad <sup>(6)</sup>	< 0.6 mrad <sup>(7)</sup>	< 0.6 mrad <sup>(7)</sup>	< 0.6 mrad <sup>(7)</sup>	< 0.6 mrad <sup>(7)</sup>	< 0.6 mrad <sup>(7)</sup>	< 0.6 mrad <sup>(7)</sup>
<b>Optical performance</b>							
Typical scan angle of scanner 1	±0.35 rad	±0.35 rad	±0.35 rad	±0.35 rad	±0.35 rad	±0.26 rad	±0.35 rad
Typical scan angle of scanner 2	±0.35 rad	±0.35 rad	±0.35 rad	±0.35 rad	±0.35 rad	±0.40 rad	±0.35 rad
Typical field size – ellipse <sup>(2), (4)</sup>	-	-	-	-	-	80 x 130 mm <sup>2</sup>	-
Typical field size – square <sup>(2), (4)</sup>	110 x 110 mm <sup>2</sup>	110 x 110 mm <sup>2</sup>	90 x 90 mm <sup>2</sup>	110 x 110 mm <sup>2</sup>	90 x 90 mm <sup>2</sup>	75 x 75 mm <sup>2</sup>	50 x 50 mm <sup>2</sup>
Nonlinearity	< 3.5 mrad / 44°	< 3.5 mrad / 44°	< 3.5 mrad / 44°	< 3.5 mrad / 44°	< 3.5 mrad / 44°	< 3.5 mrad / 44°	< 3.5 mrad / 44°
<b>Weight</b> (without objective)	approx. 3 kg <sup>(5)</sup>	approx. 3 kg <sup>(5)</sup>	approx. 3 kg <sup>(5)</sup>	approx. 3 kg <sup>(5)</sup>	approx. 5.8 kg	approx. 5.8 kg	approx. 5.8 kg

(all angles are in optical degrees)

- <sup>(1)</sup> settling to 1/1000 of full scale  
<sup>(2)</sup> with F-Theta objective, f = 160 mm respectively f = 163 mm (hurrySCAN 20-30)  
<sup>(3)</sup> at constant ambient temperature and load, without water cooling;  
 achievable even under varying load when equipped with temperature-controlled water cooling  
<sup>(4)</sup> limited by vignetting at objective  
<sup>(5)</sup> with optional water cooling up to 4.7 kg  
<sup>(6)</sup> at constant ambient conditions, plus offset drift < 30 µrad/K and gain drift < 100 ppm/K  
<sup>(7)</sup> after warm-up

## Common Specifications

<b>Repeatability</b> (RMS)	< 2 µrad
<b>Positioning resolution</b>	18 bit <sup>(8)</sup>
<b>Optical performance</b>	
Gain error	< 5 mrad
Zero offset	< 5 mrad
Skew	< 1,5 mrad
<b>Power requirements</b>	±(15+1.5) V DC, max. 3 A (max. 6 A for hurrySCAN20-30)
<b>Input signals</b>	
Digital version	SL2-100, XY2-100 Standard or optical data transfer
Analog version	alternatively: ±4.8 V; ±9.6 V; ±4.8 mA; ±9.6 mA
<b>Output signals</b>	3 status signals per axis
Digital version	SL2-100, XY2-100 Standard or optical data transfer
Analog version	TTL level
<b>Operating temperature</b>	25 °C ± 10 °C
<b>Typical air requirements<sup>(9)</sup></b>	clean, filtered air 20 l/min at Δp < 2 bar
<b>Typical water requirements<sup>(9)</sup></b>	5 l/min at Δp < 0.1 bar, p < 4 bar

(all angles are in optical degrees)

<sup>(8)</sup> based on the full angle range (e.g. positioning resolution 2.8 µrad for angle range ±0.36 rad), resolutions better than 16 bit (11 µrad) only together with SL2-100 interface

<sup>(9)</sup> air and water cooling optional for hurrySCAN III 10 and 14, hurrySCAN II 7-14 and hurrySCAN 10